

HOW DO WE SELECT SPECIES FOR CONSERVATION?

LARS HEDENÄS*

RESUMEN

Los organismos vivos sólo pueden salvarse (hasta cierto punto) a través de métodos racionales y eficientes. Podría proponerse a la diversidad genética como criterio de selección de especies para conservación; aunque es de difícil estimación, ésta podría corresponder a la diversidad morfológica, anatómica o molecular de los organismos. Los análisis cladísticos de esos datos son una buena base para preparar listas de prioridad de especies en grupos monofiléticos. La selección de las especies deberá seguir un orden tal que maximice el número de transformaciones del estado de un carácter o los pasos de un cladograma para un número dado de especies seleccionadas. Después de establecer una lista de prioridad en esta forma, las especies que pueden sobrevivir sin medidas adicionales deben excluirse de otras acciones de conservación. Una vez obtenida la lista final de selección y orden de especies, deberán seleccionarse en forma óptima las áreas donde se protejan tantas especies como sea políticamente posible. Ni la selección de las especies ni las acciones de conservación pueden realizarse a nivel nacional porque la distribución de las especies y taxa supraespecíficos rara vez coincide con los límites políticos. En grandes grupos (e.g., las familias más grandes) se pueden lograr aproximaciones con los mismos métodos para establecer órdenes de prioridad para géneros u otras unidades taxonómicas. Si se hicieran análisis grandes basados en la selección de especies en grupos pobremente conocidos, es probable que el clado(s) donde se encuentre la variación más alta incluya una proporción relativamente grande de la variación genética del grupo de organismos. Este clado deberá recibir una prioridad relativamente alta en los trabajos de conservación.

Palabras clave: análisis cladísticos, conservación, diversidad filogenética, análisis prioritarios.

ABSTRACT

The living organisms on Earth can only be saved (to some degree) with rational

* Swedish Museum of Natural History, Department of Cryptogamic Botany, Box 50007, S-104 05 Stockholm, Sweden.

and cost-efficient methods. One approach is to consider genetic diversity when selecting species for conservation measures. The actual genetic diversity is difficult to estimate in most cases, but can be assumed to correspond with the morphological, anatomical or molecular diversity of the organisms. Therefore, cladistic analyses based on such data form a good basis for making priority lists among species in monophyletic groups. Species should be selected in an order that always maximises the number of character state transformations, or steps covered on a cladogram, for a given number of species selected. After a first priority list with all species has been established in this way, species that can be assumed to survive without further measures should at present be excluded from further conservation actions. When the final selection and priority order of species has been thus achieved, the areas necessary to protect as many of these species as is politically possible should be selected in an optimal way. Neither selection of species nor conservation actions can be performed on a national basis because the distributions of species and higher taxa rarely coincide with national boundaries. In large groups (*e.g.*, larger families), approximations can be made at higher taxonomic levels with the same methods as at the species level to establish priority orders for genera or other taxonomic units. If large overview analyses based on selected species are made in less well known groups of organisms, it is suggested that the clade(s) where the greatest variation in the group is found is likely to include a relatively large proportion of the total genetic variation within the organism group. This clade should thus be given a relatively high priority in the conservation work.

Key words: cladistics, conservation, phylogenetic diversity, priority analysis.

INTRODUCTION

The motives we have for protecting species from extinction are crucial for the choice of methods in conservation work. Most, if not all people dealing with the conservation of nature have, at least partially, emotional or ethical motives for their efforts. Many earlier ideas on conservation, such as the selection of large trees or showy flowers, such as orchids, for protection had also mainly an emotional basis. These motives are important and should not be denied. However, even if some of the most basic motives for conservation work are often irrational, we cannot afford to use irrational methods when dealing with conservation in practice. Considering the number of species existing on Earth, it is impossible to spend the same amount of money for each species, and some must be selected for the primary efforts. When this is realised, the methods for choosing which species to spend the available resources on differ depending on what goal you want to reach. Many researchers in phylogeny or related fields believe that isolated, basal species in a phylogenetic tree are worth more than strongly specialised species within a more recently derived group, because ancient organisms can rarely be replaced by more modern ones in providing clues to the history of life. On the other

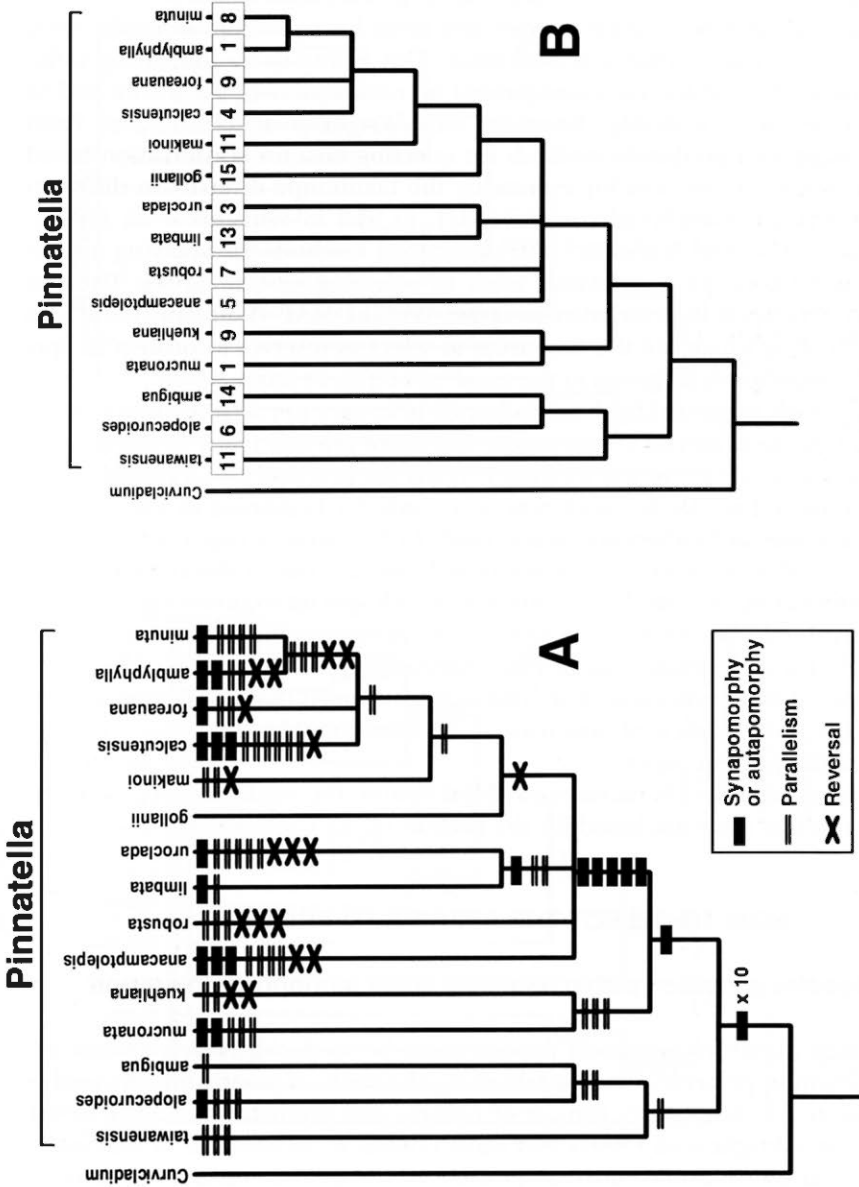

Fig. 1 A. The strict consensus tree resulting from a reanalysis of the *Pinnatella* data from Hyönönen and Enroth (1994), with character state transitions superimposed. B. The order of priority for the species (see text). When two species added the same number of steps to the taxonomic distance covered, they were given the same number in the order of selection.

hand, researchers in more applied fields, such as those looking for medically active substances, could be expected to be more interested in retaining the largest possible genetic diversity. In the latter case, interesting substances may be as likely to be found among recently derived taxa as among more ancient ones.

The question of how to select species and areas for conservation in the most cost-effective way, has become a critical issue. This is due to an increasing influence of various kinds of human management on nature all over the world, and to the limited resources available. Recently, Vane-Wright *et al.* (1991) and Faith (1992a, b) suggested predictive methods for selecting taxa for conservation based on cladistic relationships, and for estimating the taxonomic diversity in different geographical areas. Vane-Wright *et al.* (1991), as well as Williams *et al.* (1991), Pressey *et al.* (1993) and Williams (1993) described methods for applying a taxonomic diversity concept in practical work in selecting reserve areas. The last author also developed the computer program WORLDMAP (Williams, 1994) as a tool for evaluating which are the best areas to select as reserves to protect all species within a monophyletic group in the most cost-efficient way.

The approach suggested by these authors is necessary to reach the more objective goals of modern species conservation, but there are still many problems that need to be discussed before the method is ready for practical use. Probably Mays (1990) statement that "All this work represents only the beginning of what may be called the calculus of biodiversity" is still valid. In the present paper a number of issues in need of more attention are addressed, and are put in the context of the nature conservation process. The selection of which species to protect is especially discussed. It should be noted that although the present paper is based on the assumption that it is desirable that as many species as possible, and preferably all, should be saved from extinction, I am not at all convinced that this is a reasonable goal from the point of view of how nature may function. However, this is beyond the scope of the present paper.

For species that are only mentioned in the figures, the reader is referred to the revisions on which these are based for the authors of the Latin names.

HOW TO SELECT THE SPECIES TO PROTECT

A. Species selection within relatively small monophyletic groups

The first step in the conservation process must be to decide which species are most important to preserve. When establishing the order of priority for the protection of species (or other taxa), the use of rational and predictive methods, as suggested by Vane-Wright *et al.* (1991) and Faith (1992a, b), is essential. A reasonable approach is to try to save as much as possible of the genetic variation within the economical frames available (*cf.* Mishler, 1995). The only estimate we usually have of how different two taxa are, is based on the number of character states ("taxo-

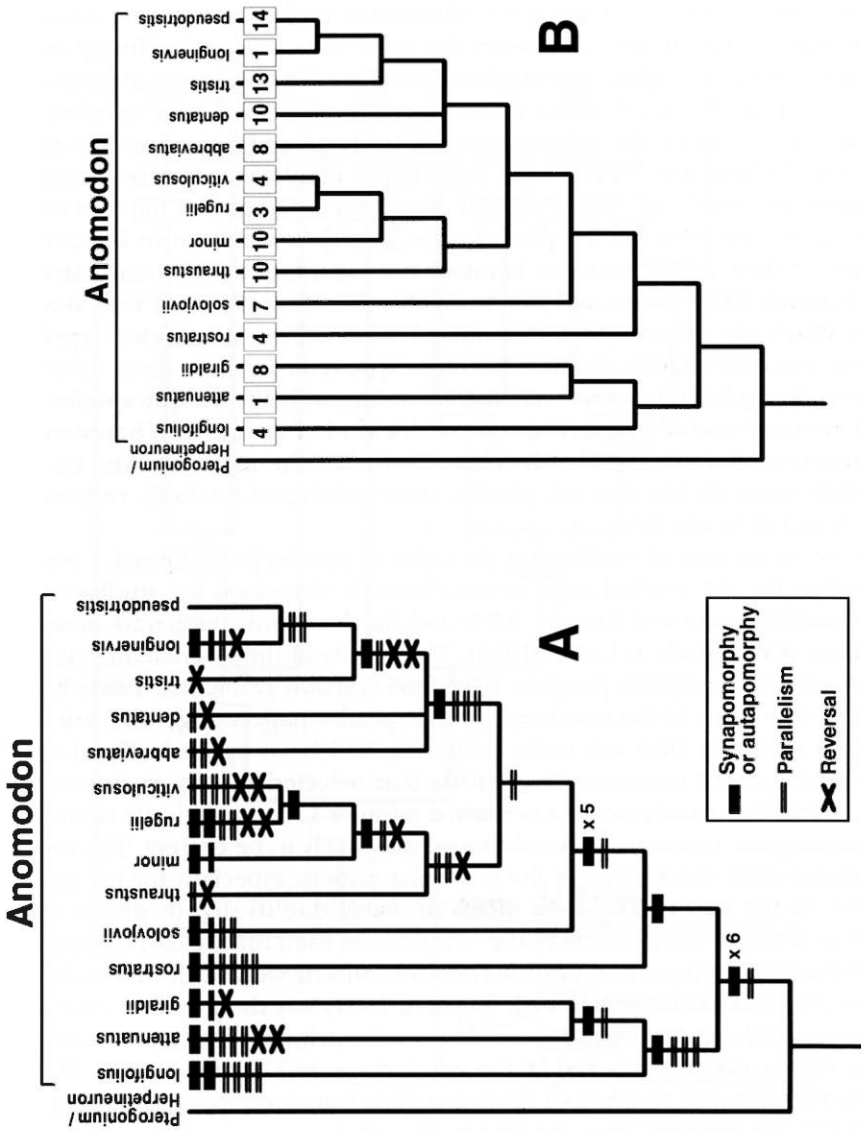

Fig. 2 A. The strict consensus tree resulting from a reanalysis of the *Anomodon* data from Granzow-de la Cerda (1992), with character state transitions superimposed. B. The order of priority for the species (see text). When two or more species added the same number of steps to the taxonomic distance covered, they were given the same number in the order of selection.

onomic distance") by which they differ. Thus, based on the cladistic relationships between species, the species separated by the highest number of steps on a cladogram should be selected first, because they can also be assumed to be phylogenetically most strongly separated. The latter assumption is valid regardless of whether the cladistic analysis is based on morphological, molecular or other data, but the correlation naturally becomes better the more data that are included in the phylogenetic evaluation. Then species should be added in an order that always maximises the total taxonomic distance covered for the number of taxa selected. The distance between taxa could be measured either in terms of the number of nodes (*e.g.*, Vane-Wright *et al.*, 1991), or in terms of the number of character state transformations (or "steps"; *e.g.*, Faith, 1992b). However, although the number of nodes is simpler to use than the number of steps, it gives a much more inexact and uncertain estimate of the distance between two taxa, especially when many steps occur between some nodes and few between other ones. In cases with isolated species which are considered differentiated from others at a higher level (*e.g.*, forming own orders), this problem becomes apparent. In these cases there would be no other branches on the branch terminating with the unique species, thus giving a low weight to all but perhaps one of this kind of species (if it happens to be a basal taxon; *cf.* Faith, 1992b). It seems likely that the method using the number of steps between two taxa (or possibly some combined method) reflects the patterns found in nature best.

To illustrate the process of establishing the order of priority just outlined, I use the available data for the tropical moss genus *Pinnatella* (based on the studies of Enroth, 1994 and Hyvönen and Enroth, 1994) and for the mainly temperate moss genus *Anomodon* (Granzow-de la Cerda, 1992). The results of the original analyses were checked with the computer program HENNIG86 (version 1.5; Farris, 1988) by reanalysing the data given in the matrices in the respective papers to get the strict consensus trees obtained after successive weighting had been applied (Fig. 1A, 2A). I am here using strict consensus trees rather than selected equally parsimonious trees on which the consensus trees are based because I see no logically sound method of choosing one tree out of several that equally likely to be correct. The results differ slightly from those given in the respective papers, especially for the genus *Anomodon*. In the case of *Pinnatella* this is probably due to slightly different approximations made by the programs PAUP—which was used for the corresponding tree published by Hyvönen and Enroth (1994)—, and HENNIG86. In this study, the computer program CULL (written by J. S. Farris, 1994) was then used to establish the priority order among the taxa according to the principles outlined above (maximal taxonomic distance covered by the selected species). From an input file with the tree structure and number of character state transformations per node, this program lists the terminal taxa (maximum 64 with the present edition of the program) in order of decreasing added taxonomic distance covered by the selected taxa (Table 1, Fig. 1B, 2B).

A problem in this context concerns the occurrence of unique autapomor-

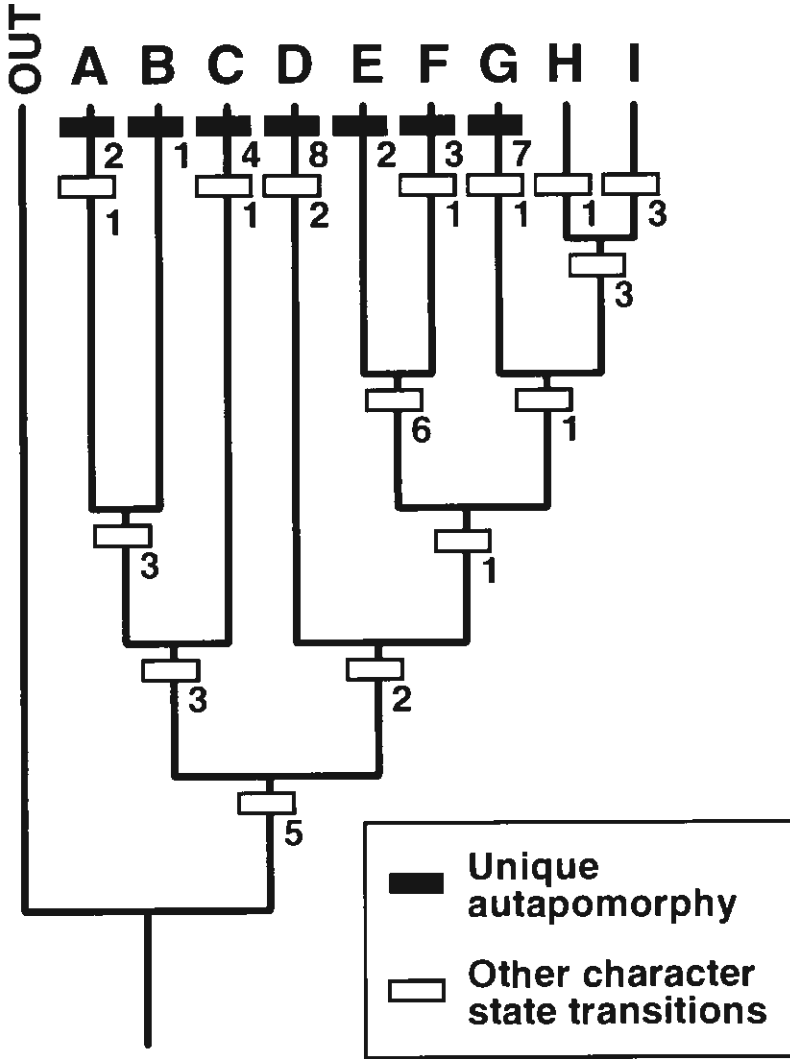

Fig. 3. Hypothetical cladogram showing the relationships between the terminal taxa A-I. OUT = outgroup. Numbers indicate the number of character state transitions (steps) of the different kinds.

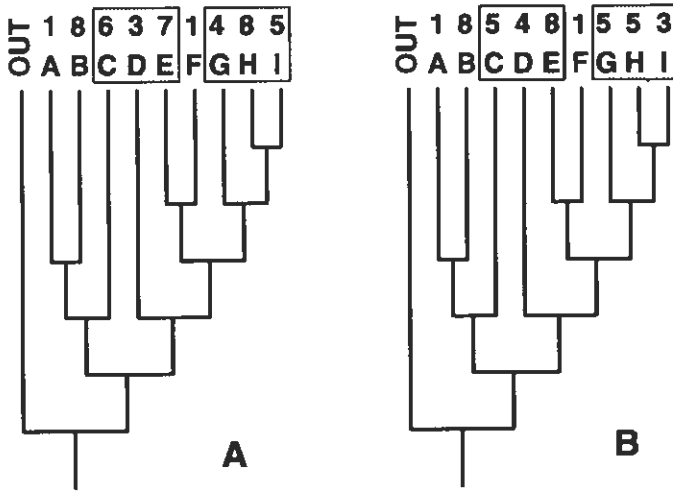

Fig. 4. The order of priority of taxa from the cladogram in Fig. 3. The order is indicated by the numbers above the taxa A-I. A: With the unique autapomorphies included. B: Without the unique autapomorphies. When two species added the same number of steps to the taxonomic distance covered, they were given the same number in the order of selection.

phies, that is, autapomorphies that occur uniquely in one terminal taxon within the entire studied monophyletic group. Characters where one state (in the case of two-state characters) occurs only in one terminal taxon are usually not included in cladistic studies because such characters are uninformative as regards the relationships between the studied taxa. Thus, if the results of most cladistic analyses are used as they mostly appear when published, species with unique autapomorphies will get a too low weight if the intention is to preserve the widest possible range of genetic diversity. On the other hand a large number of unique autapomorphies in taxa high up in the phylogenetic trees may give a too high weight to these compared with the more basal taxa (*cf.* above). In Fig. 3 and 4, a hypothetical case is shown to indicate how the inclusion or exclusion of unique autapomorphies may affect the selection of taxa for conservation. In the first case, terminal taxa with numerous unique autapomorphies, such as D and G in Fig. 3, get a high weight compared with other taxa (*cf.* Fig. 4A, B). The problem with unique autapomorphies of the terminal taxa in different conservation contexts needs to be discussed further. (The matrices of the analyses used as examples in this paper were used as they appeared in the original publications).

The establishment of the order of priority of the taxa is followed by a selection of taxa for conservation measures. This selection is mostly necessary due to limited resources, but the necessity is usually not clearly stated in studies dealing with the selection of taxa based on their phylogenetic relationships (*e.g.*, Vane-Wright *et al.*, 1991; Faith, 1992a, b). Taxa could be excluded from further conservation meas-

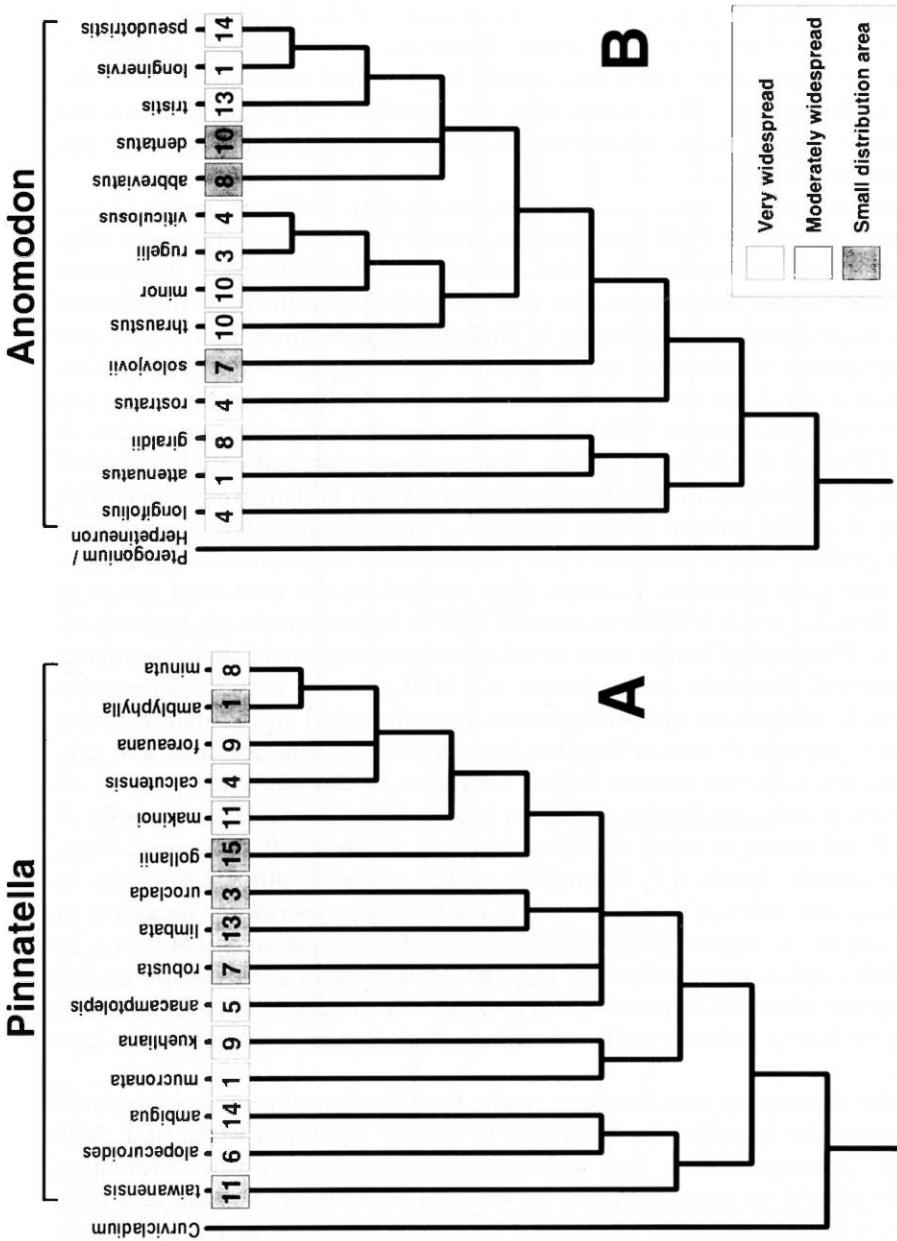

Fig. 5. Strict consensus trees, with the order of priority for the species. The size of the distribution area of the species is indicated with different shadings in the squares with the priority order indicated. A: *Pinnatella* (cf. Fig. 1, Table 2). B: *Anomodon* (cf. Fig. 2, Table 3). See text for further explanations.

ures for two basic reasons: 1) political reasons (in the widest sense), or 2) the taxa are not endangered or likely to become endangered unless very drastic and large-scale changes of the environment occur. Limitations of the first kind are clearly beyond the scope of the present discussion. However, even in the case of political limitations, the decisions of which taxa should be protected must be based on the principles outlined here. This means that, for example, the politicians and the general public must be made to understand that there are sound reasons for saving also less showy species.

The second reason is more interesting in this context, and as examples of how this may work in practice I will again use the genera *Pinnatella* and *Anomodon* (Fig. 1, 2) as examples. I use the extent of the geographical distributions of the species as an estimate of how endangered they are. Although this estimate is insufficient on its own, it serves its present purpose in illustrating the method. In Tables 2 and 3, the geographical distributions of the species in the respective genera are summarised, and in Fig. 5 the extent of the distributions are superimposed on the priority orders within the genera. Within *Pinnatella*, one of the first priority species, *P. mucronata* (Bosch & Sande Lac.) Fleisch., is also widespread, and could (provided that the geographical distribution is an indication of how endangered a species is) be assumed to survive without further measures. *Pinnatella amblyphylla* Enroth, and at the next priority level, *P. uroclada* (Mitt.) Enroth both have a restricted distribution area, and need measures to secure their survival. At the next level comes *P. calcutensis* Fleisch., which is more uncertain, due to its intermediately large distribution area. This kind of border cases need investigation to establish if they are really endangered. *Pinnatella anacamptolepis* (C. Müll.) Broth. and *P. alopecuroides* (Mitt.) Fleisch., at the next two priority levels are widespread and probably survive on their own, whereas *P. robusta* Nog. has again a small distribution area and cannot be expected to survive without further measures. In this way a new priority order of species to select for further measures can be established as *P. amblyphylla*, *P. uroclada*, (*P. calcutensis*; in need of further studies), *P. robusta*, *P. taiwanensis* Nog., (*P. makinoi* (Broth.) Broth.), *P. limbata* Dix. and *P. gollanii* Broth. (cf. Fig. 5A). In the same way, the order of species to select for further conservation measures in *Anomodon* will be (*A. longinervis* Broth.), *A. solovjovii* Laz., *A. abbreviatus* Mitt., (*A. giraldii* C. Müll.) and *A. dentatus* Gao (cf. Fig. 5B). How many of these species we can afford to spend effort on in practice still depends on the resources available, but in this way we have a rational way for deciding which species we should try to save first.

Once the selection of taxa has been made, the selection of reserve areas could be made using, for example, the "Richness in species" option in WORLDMAP (Williams, 1994). However, rather than including all taxa in a group when evaluating which areas should be protected, only as many as possible of the taxa that **both** contribute as much as possible to the total taxonomic distance, **and** are not likely to survive without conservation measures should be included in the priority area analysis. Because the "Richness in characters" and "Richness in character combi-

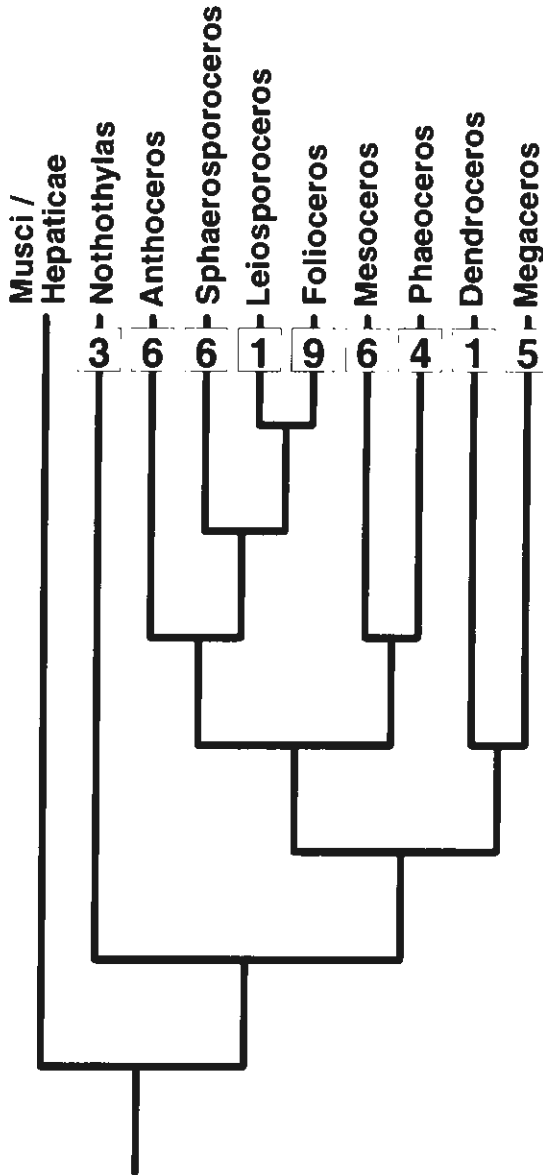

Fig. 6. Strict consensus trees, with the order of priority for the genera of Anthocerotae (see text), based on the analysis by Hyvönen and Piippo (1993). When two or more genera added the same number of steps to the taxonomic distance covered, they were given the same number in the order of selection.

nations" options in WORLDMAP are based on the number of nodes between the terminal taxa or the overall structure of the cladograms of the organisms rather than on the actual character state transitions (*cf.* above), the latter two options may need some refinement before they can be applied in practice.

B. Procedures with large monophyletic groups

In larger groups of less well known organisms, especially many so called "lower" plants and animals, the lack of understanding of the phylogenetic patterns present is a serious problem when species are chosen for conservation. This problem necessarily demands further taxonomic studies (and thus taxonomists) in order to attain a reasonable theory of the relationships between the organisms in question. However, since it is not reasonable to await a complete knowledge of most less well known organism groups before measures are taken for their conservation, other approaches must be discussed. When larger groups of taxa are involved, problems that are due to the large number of species add to the difficulties.

One way of coping with some of the problems related to large numbers of species in a monophyletic study group is to approach the group in a hierarchical way, that is, to start the selection of taxa at, for example, the family or genus level and then discuss how the units first studied are best represented by their constituent genera and species. For example, to get the Anthocerotae well represented, suitable species of the genera *Dendroceros* and *Leiosporoceros* should be selected first, and then *Nothothylas*, etc., in the order indicated in figure 6 (cladogram based on Hyvönen and Piippo, 1993; a more recent cladistic study of the Anthocerotae by Hasegawa, 1994, gave similar results). If we are interested mainly in preserving as much as possible of the genetical variability in the entire group, one weakness in this approach is that species having numerous apomorphic traits within the genera used as terminal taxa will be given a relatively low weight. This problem cannot be solved without taxonomic studies of the respective genera, but the suggested approach can be used as a first approximation in the search for which taxa should be given a high priority for conservation efforts.

If the phylogenetic relationships in a larger (supposedly) monophyletic group are insufficiently known, even less exact methods may be necessary as a first estimate of which taxa should be given a high priority for further studies. As an example, the group "pleurocarpous mosses" can be investigated (Fig. 7), based on an overview study by Hedenäs (in press). In the cladogram, the taxa selected first in a priority analysis are shown, with different numbers or symbols. It is evident that species in some parts of the cladogram add more to the total number of steps. If the 18 species with the highest priority are included, five out of thirteen taxa within the Hookeriales-Sematophyllaceae clade (Fig. 7A) are included among those selected, whereas only two out of eleven would be selected in the Amblystegiaceae-Hypnaceae-Thuidiaceae clade (Fig. 7B) with the same "conservation effort". If the 28 highest priority species are included, the first of these clades would

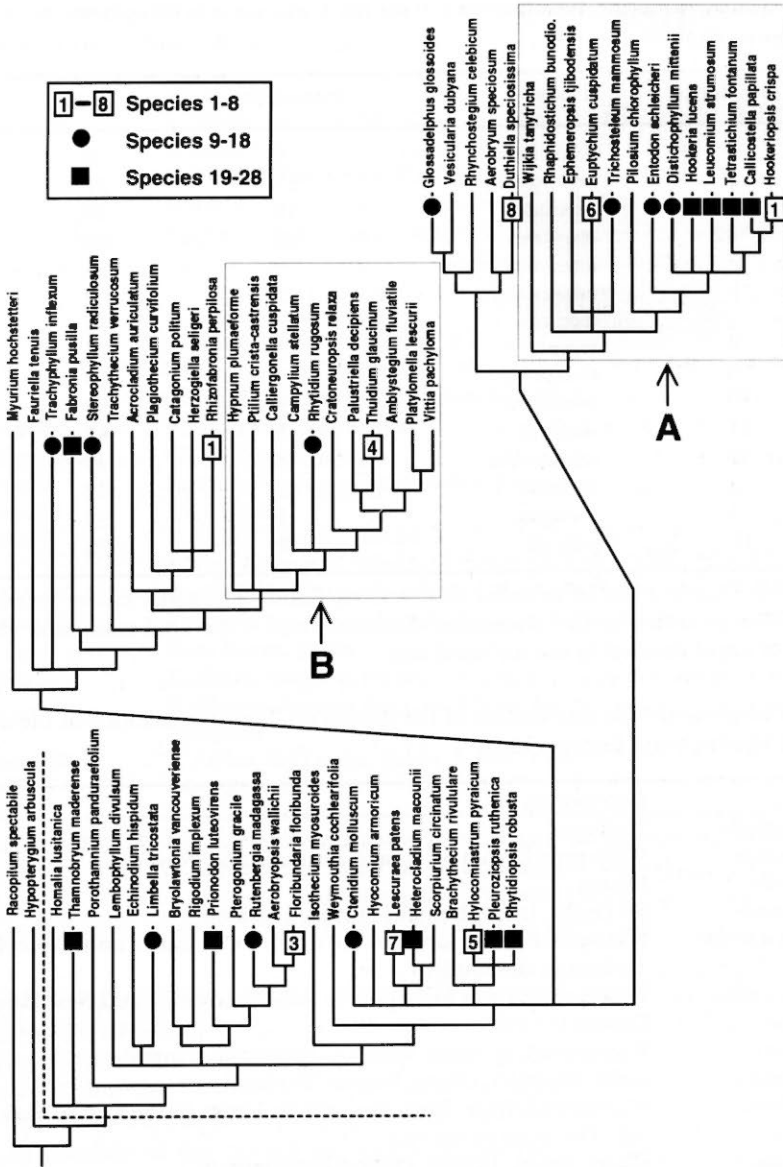

Fig. 7. The strict consensus tree from analysis no. 6 in the overview study of the pleurocarpous mosses in Hedenäs (in press). A: "The Hookeriales-Sematophyllaceae clade". B: "The Amblystegiaceae-Hypnaceae-Thuidiaceae clade". Species 2-8 add between 95 and 15 steps per species with number of steps largest between the first two species (1 and 2) and smallest between the last two. Species 9-18 add 12-8 steps per species and species 19-28 add 7-6 steps.

Table 1. Format of output files from the program CULL, using the analysis of *Pinnatella* (Fig. 1) as an example

#Included	Taxon	Increment	Total
1	<i>mucronata</i>	0	0
2	<i>amblyphylla</i>	27	27
3	<i>uroclada</i>	12	39
4	<i>calcutensis</i>	10	49
5	<i>anacamptolepis</i>	9	58
6	<i>alopecurooides</i>	7	65
7	<i>robusta</i>	6	71
8	<i>minuta</i>	5	76
9	<i>kuehliana</i>	4	80
10	<i>foreauana</i>	4	84
11	<i>makinoi</i>	3	87
12	<i>taiwanensis</i>	3	90
13	<i>limbata</i>	2	92
14	<i>ambigua</i>	1	93
15	<i>gollanii</i>	0	93

* #Included = taxon number in order of selection. Taxon = terminal taxon. Increment = number of steps added to the taxonomic distance. Total = the total taxonomic distance (number of steps) covered by the included taxa.

Table 2. The geographical distribution of the species of *Pinnatella* included in the cladistic analysis of Hyvönen and Enroth (1994)

Species	Distribution area
1. <i>amblyphylla</i>	Thailand
1. <i>mucronata</i>	Widespread, from SE Asia to Australia and Polynesia
3. <i>uroclada</i>	Burma
4. <i>calcutensis</i>	Sri Lanka, India, Bhutan, Burma, Thailand
5. <i>anacamptolepis</i>	Widespread, from Japan in the north to Sri Lanka and Papua New Guinea in the south
6. <i>alopecurooides</i>	Widespread, from India and SE Asia to Australia and New Caledonia
7. <i>robusta</i>	Taiwan
8. <i>minuta</i>	Widespread, in South America, Africa and S India
9. <i>foreauana</i>	India, (Nepal?), China, Burma, Thailand
9. <i>kuehliana</i>	Widespread, from Seychelles and Sri Lanka in the west to Malesia and Polynesia in the east
11. <i>makinoi</i>	China, Japan, Taiwan, Philippines, Vietnam
11. <i>taiwanensis</i>	Taiwan, Vietnam
13. <i>limbata</i>	SW India
14. <i>ambigua</i>	Widespread in SE Asia
15. <i>gollanii</i>	N India

* The species are listed in order of decreasing contribution to the number of steps in the cladogram (cf. Fig. 1). The table is based on information in Enroth (1994).

Table 3. The geographical distribution of the species of *Anomodon* included in the cladistic analysis of Granzow-de la Cerda (1992)

Species	Distribution area
1. <i>attenuatus</i>	E. North America, Mexico, Guatemala, Cuba, Jamaica, Santo Domingo, Europe, Caucasus, Iran, Kashmir, C. Asia, S. Siberia
1. <i>longinervis</i>	S. Siberia, Russian Far East, Korea, Japan, Taiwan
3. <i>rugelii</i>	North America, Europe, Caucasus, India, Nepal, S. Siberia, Russian Far East, China, Korea, Japan, Vietnam
4. <i>longifolius</i>	Europe, Caucasus, S. Siberia, Russian Far East, Japan
4. <i>rostratus</i>	E. North America, Mexico, Guatemala, Haiti, Jamaica, Bermuda, C. Europe, Caucasus
4. <i>viticulosus</i>	E. North America, Mexico, Europe, Canary Islands, N. Africa, Caucasus, Iran, Pakistan, C. Asia, India, Nepal, Bhutan, S. Siberia, China, Korea, Japan, Vietnam, Burma
7. <i>solovjovii</i>	Russian Far East, Korea
8. <i>abbreviatus</i>	China, Korea, Japan
8. <i>giraldii</i>	Russian Far East, China, Korea, Japan
10. <i>dentatus</i>	NE China
10. <i>minor</i>	E. North America, Mexico (var. <i>minor</i> in North America), India, Nepal, Bhutan, S. Siberia, Russian Far East, China, Korea, Japan, Burma (var. <i>integerrimus</i> (Mitt.) Iwats. in Asia)
10. <i>thraustus</i>	E. North America, Mexico, Pakistan, India, S. Siberia, Russian Far East, Korea, Japan
13. <i>tristis</i>	E. North America, Mexico, S. Europe, Caucasus, India, Nepal, Tibet, S. Siberia, Russian Far East, China, Korea, Japan, Taiwan, Hawaii, Polynesia
14. <i>pseudotristis</i>	S. Africa, Sri Lanka, Korea, Japan, Taiwan, Vietnam, Australia, New Zealand

*The species are listed in order of decreasing contribution to the number of steps in the cladogram (cf. Fig. 2). The table is based on information in Iwatsuki (1958), Watanabe (1972), Smith (1978), Crum and Anderson (1981), Vohra (1983), Duell (1985), Granzow-de la Cerda (1989), Noguchi (1991), Ignatov and Afonina (1992) and Sharp *et al.* (1994).

be represented by nine species, whereas the second would still only be represented by two species. This reflects the fact that the variation in terms of character state transformations is larger in the first than in the second of these clades, and gives a hint that the Hookeriales-Sematophyllaceae may be worth more conservation effort than the Amblystegiaceae-Hypnaceae-Thuidiaceae if we want to save as much as possible of the overall phylogenetic diversity present among the pleurocarpous mosses. The first clade (Fig. 7A) is also best represented in tropical areas, whereas the second (Fig. 7B) is best represented in more temperate areas. If this should be the result also of other analyses (*i.e.*, if the present result is not based on a biased selection of species), it would imply that tropical areas should be given a relatively large proportion of the resources in the work with saving the genetic diversity present among the pleurocarpous mosses.

FURTHER IMPLICATIONS FOR CONSERVATION WORK

With this approach to conservation, taxonomic knowledge is essential. Only with a good knowledge of the phylogenetic relationships between the organisms is it possible to select which species are most important if we want to save as much as possible of Earth's genetic diversity in an efficient way. The actual measures for protecting the selected organisms have still to be evaluated within other biological disciplines, such as ecology or genetics, but the latter are less well suited for the first selection process than taxonomy. It is evident that a global approach is mostly necessary because the distributions of taxa rarely coincide with national boundaries. Neither the establishment of priority orders of which taxa to select for conservation actions, nor the actual implementation of conservation measures for the selected species can be based solely on the conditions in single countries.

ACKNOWLEDGEMENTS

I thank J. S. Farris for writing the program CULL which was a prerequisite for this paper, and for help with other computer program problems in this context. C. J. Humphries and P. H. Williams put an evaluation copy of the program WORLDMAP at my disposal. I. Bisang provided valuable comments on an early version of the manuscript. The expenses for my trip to Mexico were partly covered by IUCN.

LITERATURE CITED

- CRUM, H. A. AND L.E. ANDERSON. 1981. *Mosses of eastern North America*. Vol. 2. New York.
- DUELL, R. 1985. Distribution of the European and Macaronesian mosses. Part II. *Bryol. Beitr.* 5: 110-232.
- ENROTH, J. 1994. A taxonomic monograph of the genus *Pinnatella* (Neckeraceae, Bryopsida). *Acta Bot. Fenn.* 151: 1-90.
- FAITH, D. 1992a. Conservation evaluation and phylogenetic diversity. *Biol. Conserv.* 61: 1-10.
- FAITH, D. 1992b. Systematics and conservation: on predicting the feature diversity of subsets of taxa. *Cladistics* 8: 361-373.
- FARRIS, J.S. 1988. *HENNIG86. Version 1.5*. (Place of issue not stated).
- GRANZOW-DE LA CERDA, I. 1989. Notes on five species of *Anomodon*, some with erroneous identity, including two new combinations. *Bryologist* 92: 381-386.
- GRANZOW-DE LA CERDA, I. 1992. Análisis cladístico de la familia Anomodontaceae. *Trop. Bryol.* 6: 95-104.
- HASEGAWA, J. 1994. New classification of Anthocerotae. *J. Hattori Bot. Lab.* 76: 21-34.
- HEDENÅS, L. (in press). Higher taxonomic level relationships among diplolepidous pleurocarpous mosses - a cladistic overview. *J. Bryol.*
- HYVÖNEN, J. AND J. ENROTH. 1994. Cladistic analysis of the genus *Pinnatella* (Neckeraceae, Musci). *Bryologist* 97: 305-312.

- HYVÖNEN, J. AND S. PIPPO. 1993. Cladistic analysis of the hornworts (Anthocerotophyta). *J. Hattori Bot. Lab.* 74: 105-119.
- IGNATOV, M.S. AND O.M. AFONINA. 1992. Check-list of mosses of the former USSR. *Arctoa* 1: 1-85.
- IWATSUKI, Z. 1958. Correlations between the moss floras of Japan and the southern Appalachians. *J. Hattori Bot. Lab.* 20: 304-352.
- MAY, R.M. 1990. Taxonomy as destiny. *Nature* 347: 1129-130.
- MISHLER, B.D. 1995. Plant systematics and conservation: science and society. *Madroño* 42: 103-113.
- NOGUCHI, A. 1991. *Moss flora of Japan*. Part 4. Hattori Botanical Laboratory Nichinan, Japan.
- PRESSEY, R.L., C.J. HUMPHRIES, C.R. MARGULES, R.I. VANE-WRIGHT AND P.H. WILLIAMS. 1993. Beyond opportunism: key principles for systematic reserve selection. *Trends in Ecology and Evolution* 8: 124-128.
- SHARP, A. J., H. CRUM AND P.M. ECKEL. 1994. The moss flora of Mexico. Part two. *Mem. New York Bot. Gard.* 69: I-VIII. 581-1113. I-XVII.
- SMITH, A.J.E. 1978. *The moss flora of Britain and Ireland*. Cambridge.
- VANE-WRIGHT, R.I., C.J. HUMPHRIES AND P.H. WILLIAMS. 1991. What to protect? - Systematics and the agony of choice. *Biol. Conserv.* 55: 235-254.
- VOHRA, J.N. 1983. Hypnobryales suborder Leskeineae (Musci) of the Himalayas. *Rec. Bot. Surv. India* 23: I-III. 1-336.
- WATANABE, R. 1972. A revision of the family Thuidiaceae in Japan and adjacent areas. *J. Hattori Bot. Lab.* 36: 171-320.
- WILLIAMS, P.H. 1993. Measuring more of biodiversity for choosing conservation areas, using taxonomic relatedness. In: T.-Y. Moon (ed.), *International Symposium on Biodiversity and Conservation (KEI)*. Korean Entomological Institute, Seoul. pp. 194-227.
- WILLIAMS, P.H. 1994. Using WORLDMAP. *Priority areas for biodiversity*. Version 3. London (privately distributed).
- WILLIAMS, P.H., C.J. HUMPHRIES AND R.I. VANE-WRIGHT. 1991. Measuring biodiversity: taxonomic relatedness for conservation priorities. *Australian Syst. Bot.* 4: 665-679.